

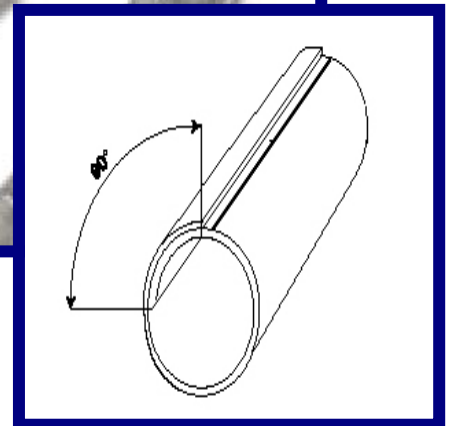

Roundit™ 2000FR Assembly Guide



Before using this guide, all customers have to verify accordance with their own harness manufacturing rules.

1 - Application

2 - Sleeve Installation on a Harness

2.1 - Preparation of the Wire Harness

2.1.1 - Bundles

2.1.2 - Cutting

2.1.3 - Tools

2.1.4 - Installation

2.1.5 - Twisting

2.2 - Diameters of Bundles/Sizes

2.3 - Fixation of the sleeve

2.4 - Branches

3 - Harness Installation

4 - Maintenance, Modifications & Repairs

4.1 - Maintenance/Modifications

4.2 - Repairs

5 - Use of the Roundit[®]-Tool

1 - Application

The sleeve **Roundit 2000FR** can be used as a :

- **mechanical protection** and **bundling** for electrical harnesses
- **over-protection** in areas of high maintenance activity
- **added protection** during the integration of the harnesses for harnesses manufactured without protection

Use of **Roundit 2000FR** has to be thought in a global accessible system, including access of the cable ties and fixation to give the possibility to make repairs and modifications.

2 - Sleeve Installation on a Harness

2.1 - Preparation of the Wire Harness

2.1.1 - Bundles

The wire bundles have to be prepared before installing **Roundit 2000FR**.

To help with installation, some break-out bundles can be tied to hold the wires in place.

This operation should be done minimally, using as little cable ties as possible since the complete harness with the sleeve will be tied after the installation of **Roundit 2000FR**.

2.1.2 - Cutting

Roundit 2000FR is cut with scissors and has an anti-fray system with a knot at the edge.

Good paper quality scissors are requested in order not to generate damage to **Roundit 2000FR** during cutting.

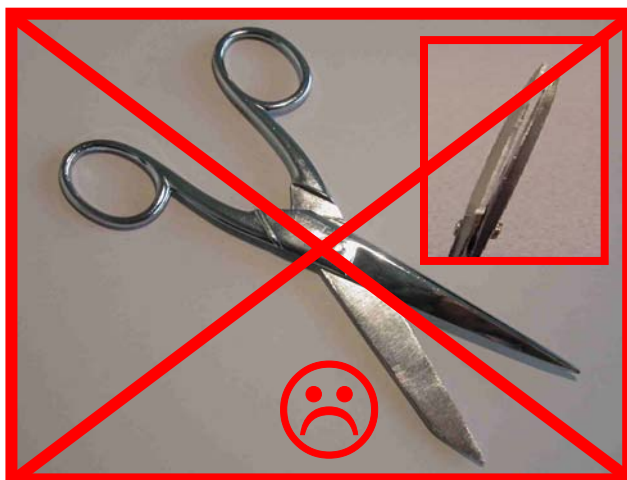

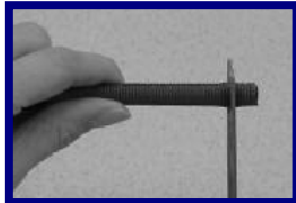

1 Make one straight cut across the width of **Roundit 2000FR**



2 Using very light force, manually pull the loose fibers off the end of the cut edge



3 Pull any remaining loose fiber over to tracer edge of **Roundit 2000FR**. Filaments will stop unraveling. Cut off with scissors.

Go back to step 1 if final cut is not straight

2.1.3 - Tools

2 tool designs can be used to facilitate the installation of **Roundit 2000FR** on bundles for sizes below 25 while removal of the sleeve can be performed manually without tools.



Use of the tools is explained in section 5

2.1.4 - Installation

Roundit 2000FR on the bundle must be **tight** in order not to generate folds.

To make it easier for multi-branch harnesses, it is better to start covering the smallest bundle and finish with the biggest. This makes it possible to cover the small size by a bigger size on the break-out.

2.1.5 - Twisting

Roundit 2000FR must be **twisted on all bundles**.

The **twist** shall be on average around **3 to 4 turns per linear meter** (1 turn/ft) of the bundle.

The **number of turns can be increased** to adapt the diameter of **Roundit 2000FR** to a smaller bundle.

2.2 - Diameters of Bundles/Sizes

Roundit 2000FR sizes must be adapted to suit the diameters of the bundles so that, in all cases, lip overlap is 130° maximum and 65° minimum. Overlap is 90° on nominal size.

Sizes mm (inches)	Bundle Diameter	
	Max mm (inches)	Min mm (inches)
5 (3/16")	5 (3/16")	1 (1/32")
8 (5/16")	8 (5/16")	5 (3/16")
13 (1/2")	13 (1/2")	8 (5/16")
19 (3/4")	19 (3/4")	13 (1/2")
25 (1")	25 (1")	19 (3/4")
29 (1-1/8")	29 (1-1/8")	25 (1")
32 (1-1/4")	32 (1-1/4")	29 (1")
38 (1-1/2")	38 (1-1/2")	32 (1-1/4")
50 (2")	50 (2")	38 (1-1/2")

Roundit 2000FR from the side :

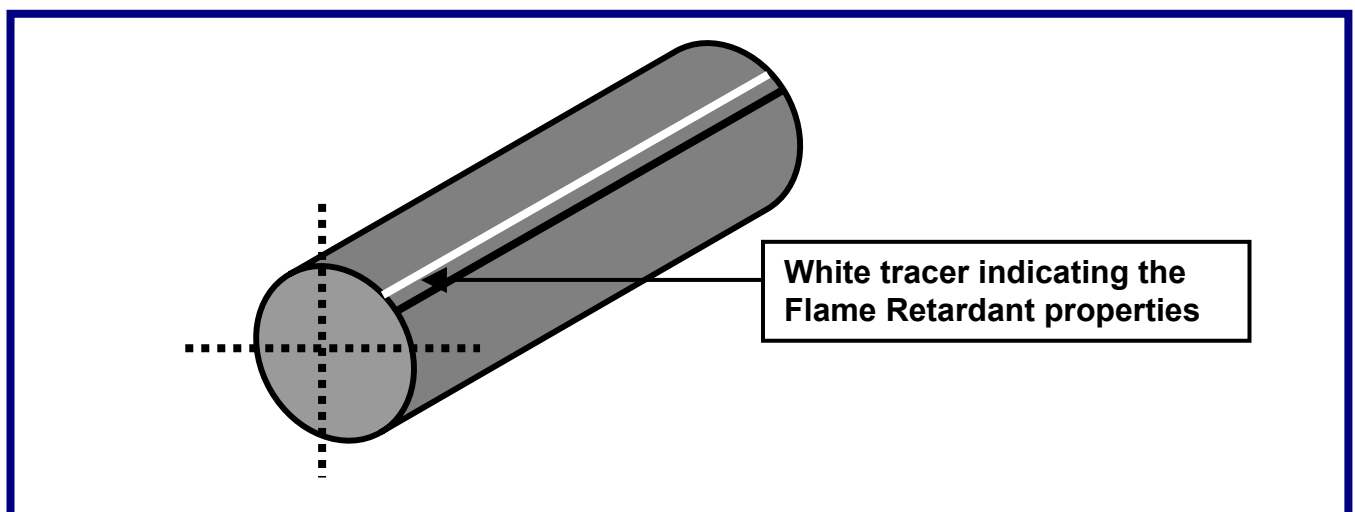

Roundit 2000FR installed on a wire harness :

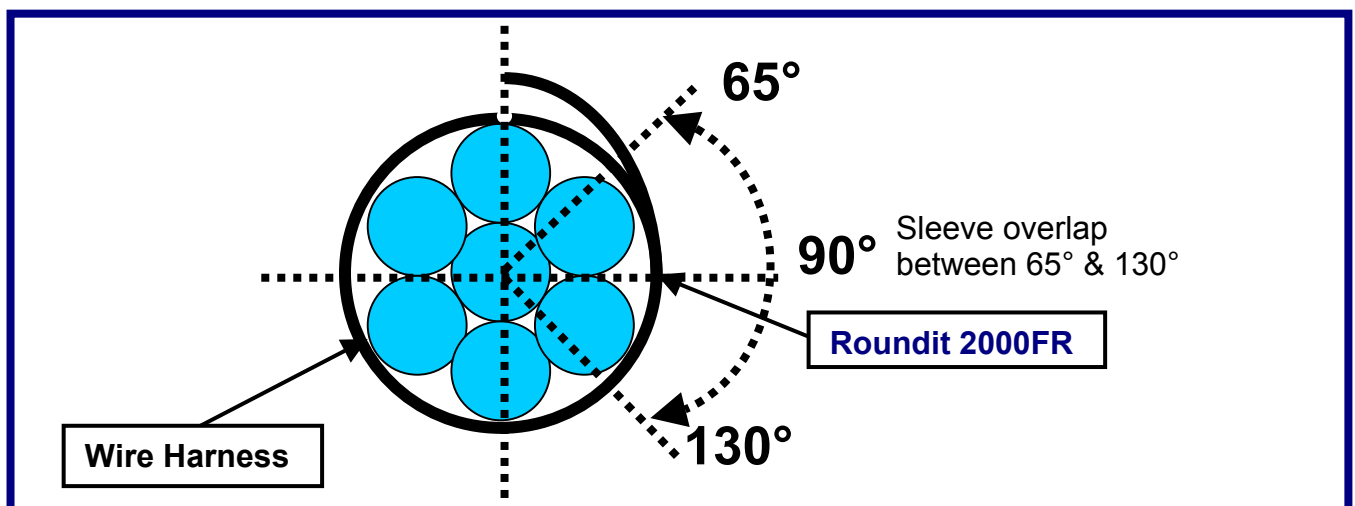

2.3 - Fixation of the sleeve

Roundit 2000FR bundle connections are made with cable ties or lacing tapes.

The cable tie or lacing tape interval is **15 cm on the end** and **on the dynamic areas** of the harness.

The interval **can be increased to 50 cm max on the static areas** of the harness.

The **fixation** of the harness **will increase the quantity of cable ties**.

Roundit 2000FR terminations have to be done with a tie at 2 cm from the ends of the sleeve. A silicone tape 67N can be added to finish the ends :

A cable tie can be added to the bundle near the ends of **Roundit 2000FR** to stop the sleeve from moving on the bundle (if necessary).



1 → Single harness

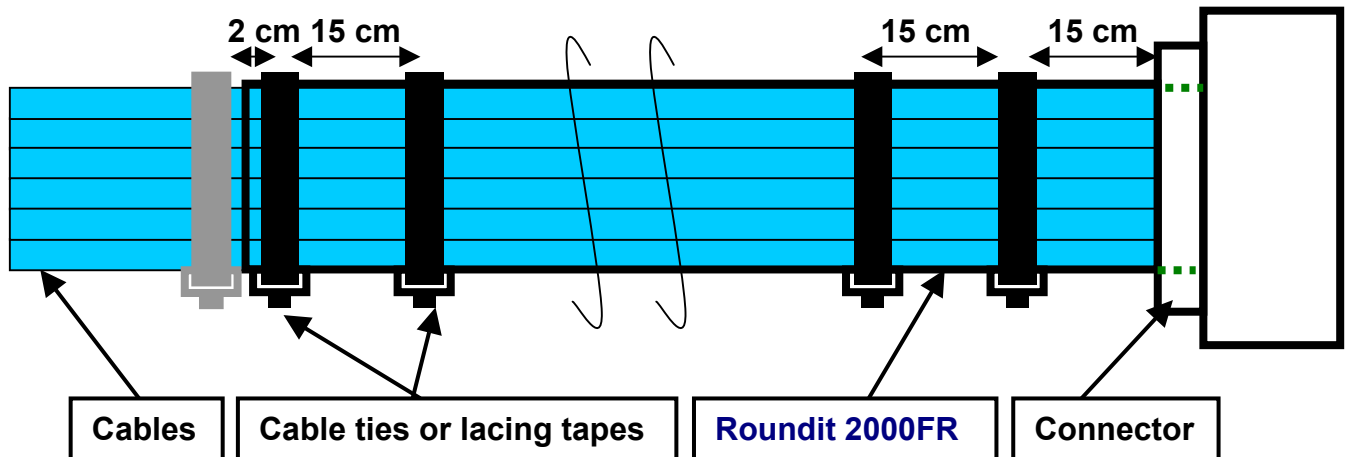

2.4 - Branches

2 → Multiple branches: 2 small **Roundit 2000FR** & 1 big

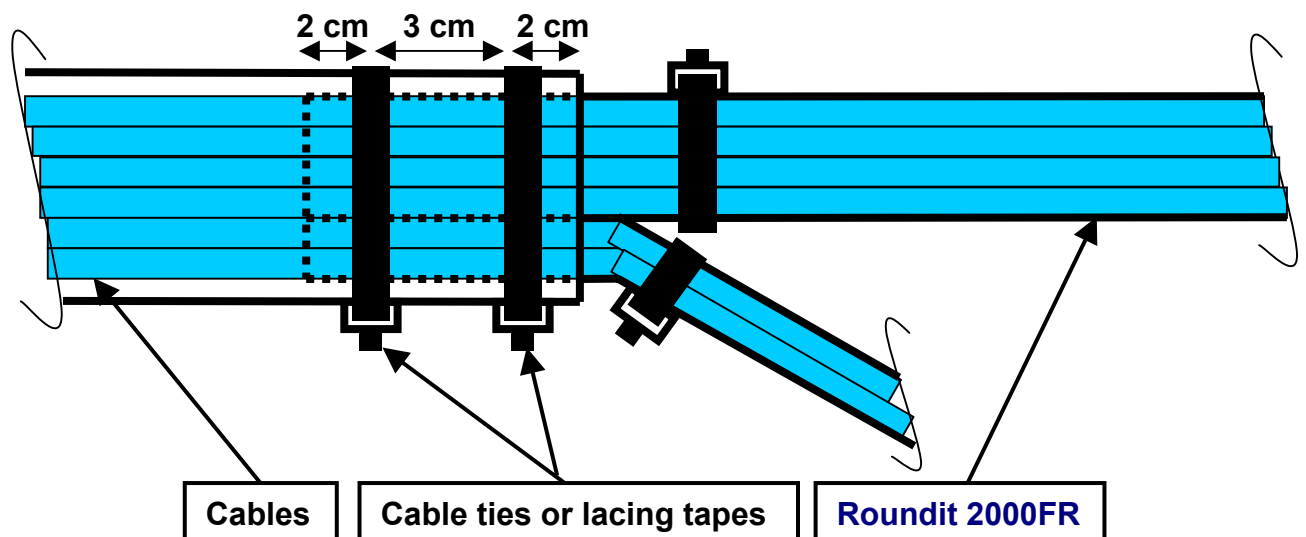

3 → Single branch **Roundit 2000FR / Roundit 2000FR**

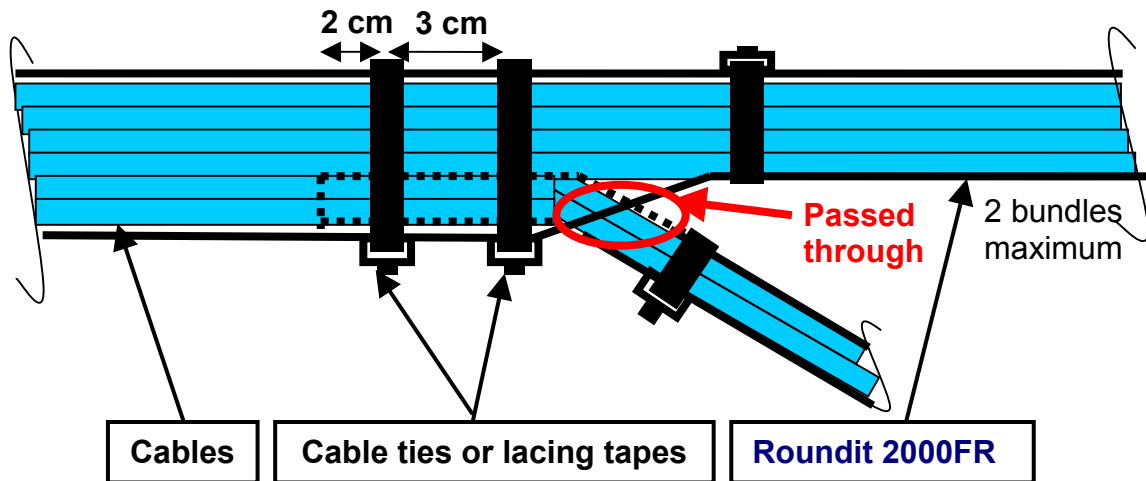

4 → Single branch **Roundit 2000FR / unprotected bundle**

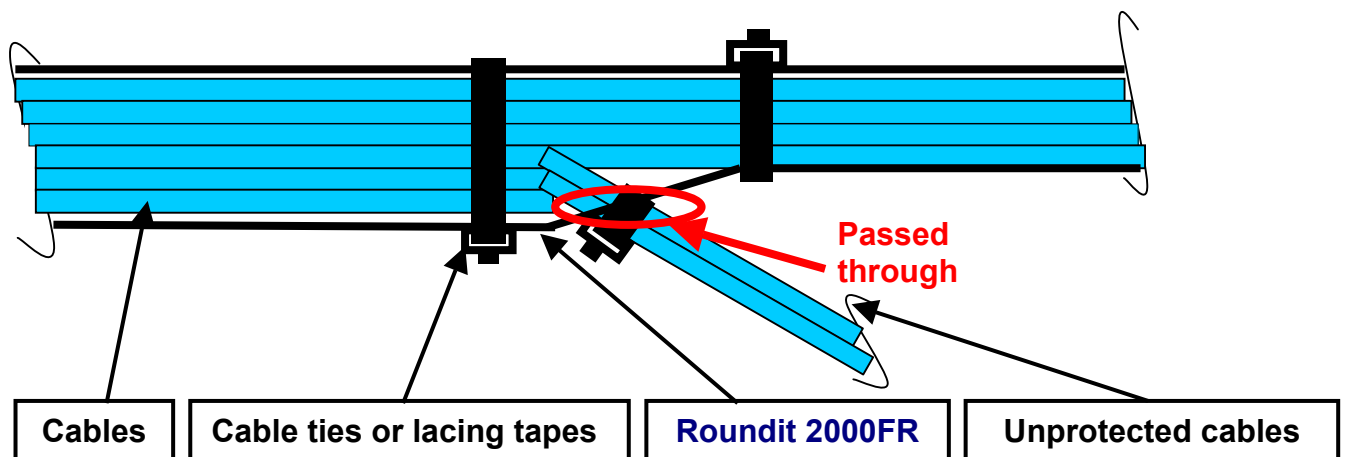

5 → Single branch : unprotected bundle / **Roundit 2000FR**

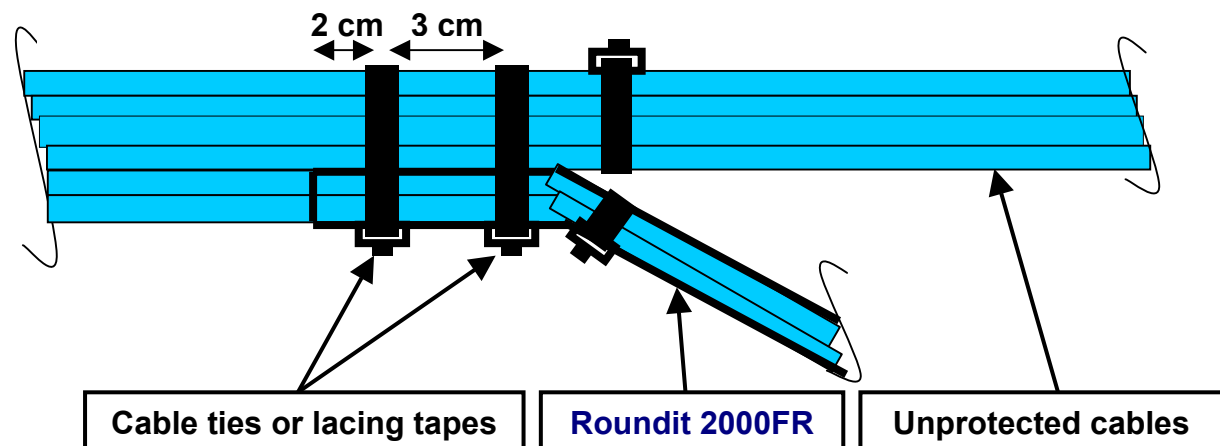

3 - Harness Installation on Car

The radii of curvature of the harnesses are not affected by the use of the **Roundit 2000FR**. It is defined by value applicable on the wire.

Drain holes are not required on the low points of bundles protected with **Roundit 2000FR**. It can be made if necessary in a specific area.

Fixing the harness will add more cable ties on **Roundit 2000FR**. This should be taken into account when you install cable ties or lacing tapes to secure **Roundit 2000FR** on the bundles.

During the installation you must take care of all unprotected harnesses. This is the right time to verify if there is a need to add **Roundit 2000FR** in short lengths for all harnesses showing chaffing risks.

4 - Maintenance, Modifications & Repairs

4.1 - Maintenance/Modifications

Adding or removing some wires is easier after cutting some cable ties and opening the **Roundit 2000FR**. Adding a wire may require the use of the tools.

It is possible to replace **Roundit 2000FR** without removing the harness.

Installation / removal of **Roundit 2000FR** can be performed manually or with a Roundit[®] Tool.

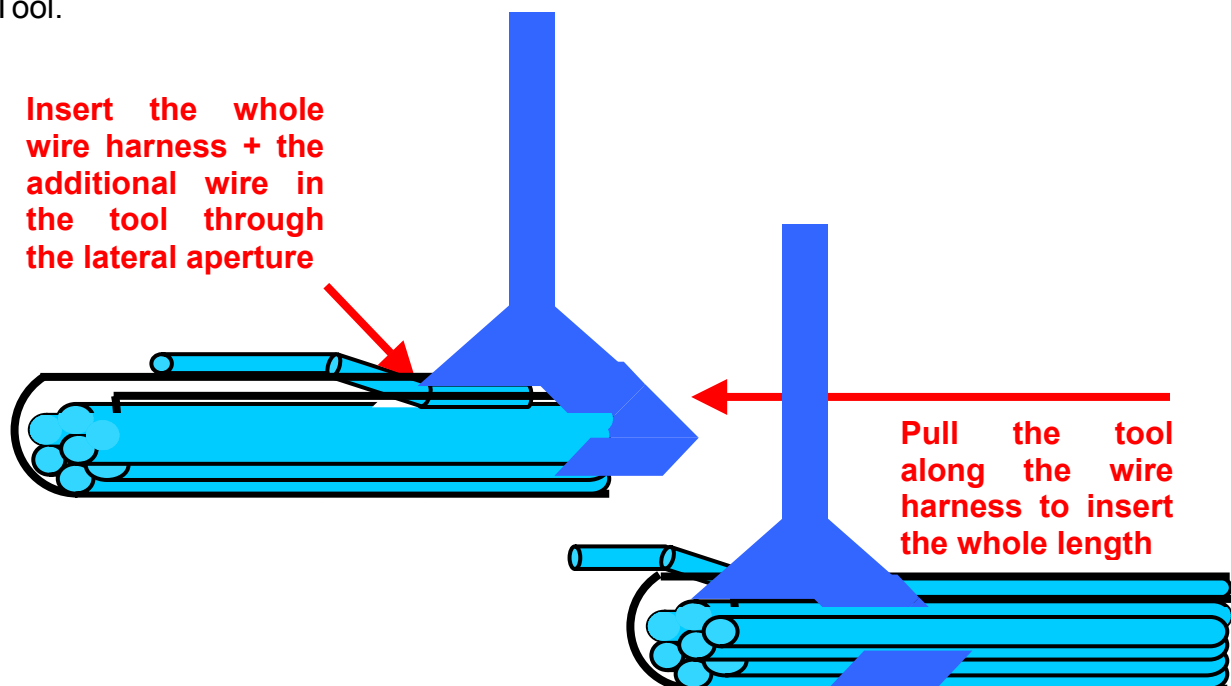

Operations on end items: It is possible to partially open **Roundit 2000FR** on only the required sections.

4.2 - Repairs

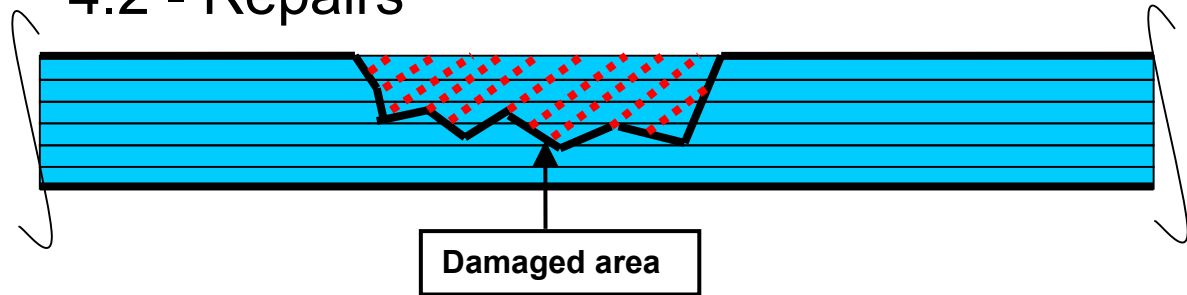

1 → By taking off the sleeve and replacing by **Roundit 2000FR**

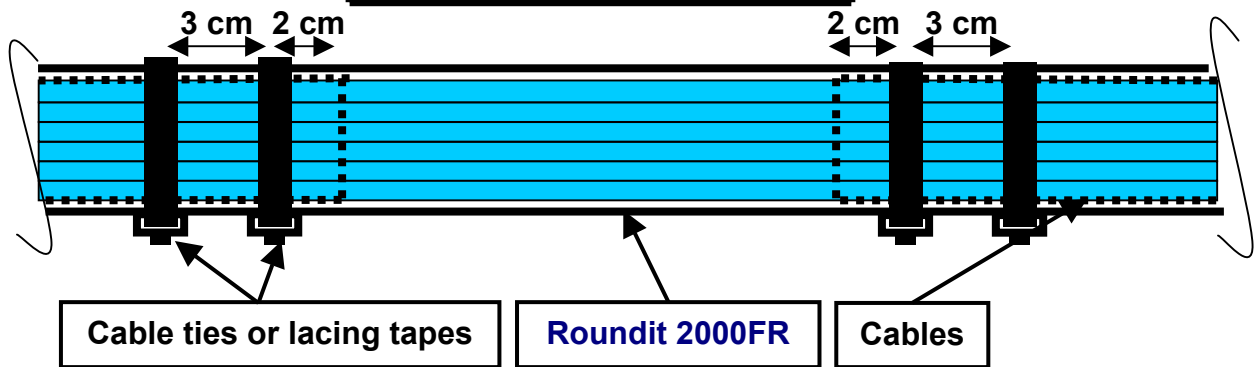
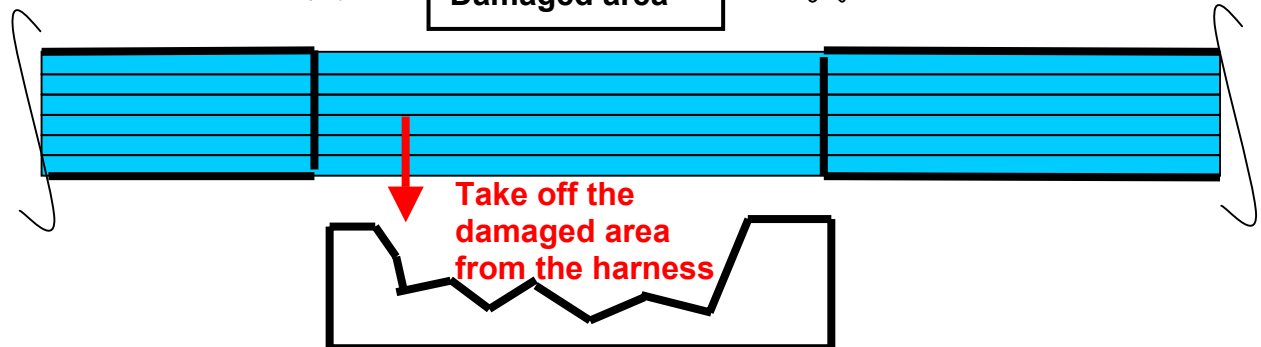
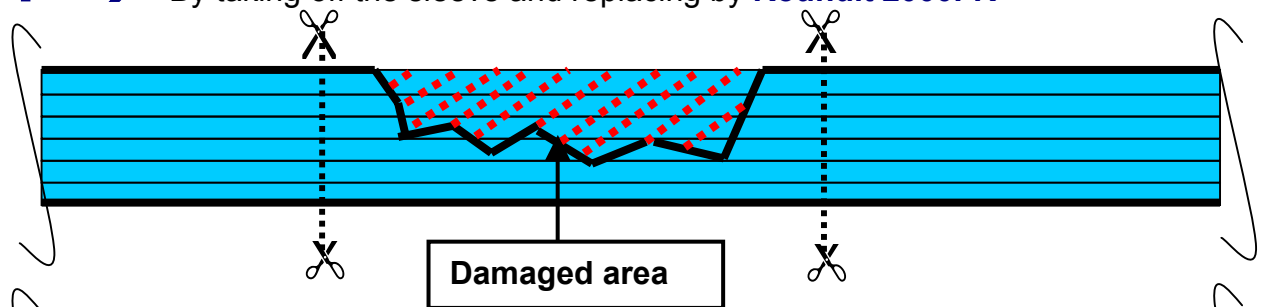

2 → By over-sleeving **Roundit 2000FR** on the damaged area

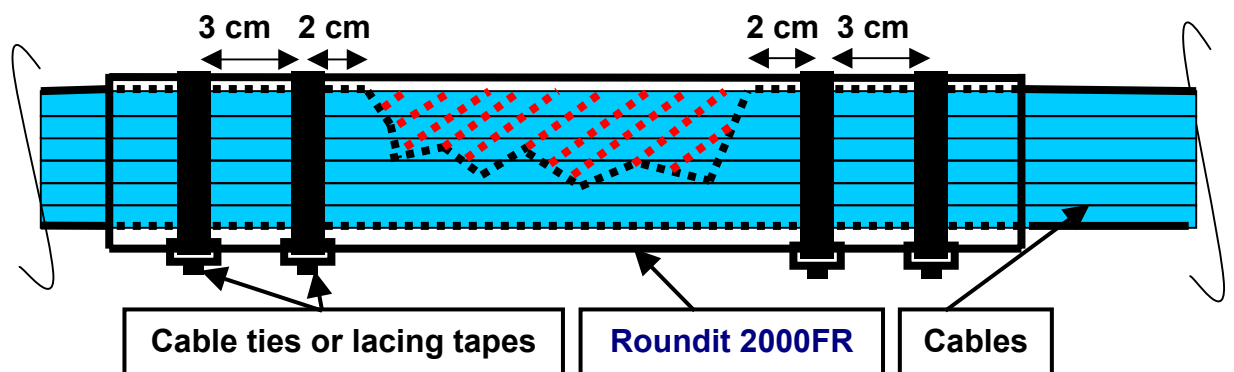

5 - Use of the Roundit®-Tool

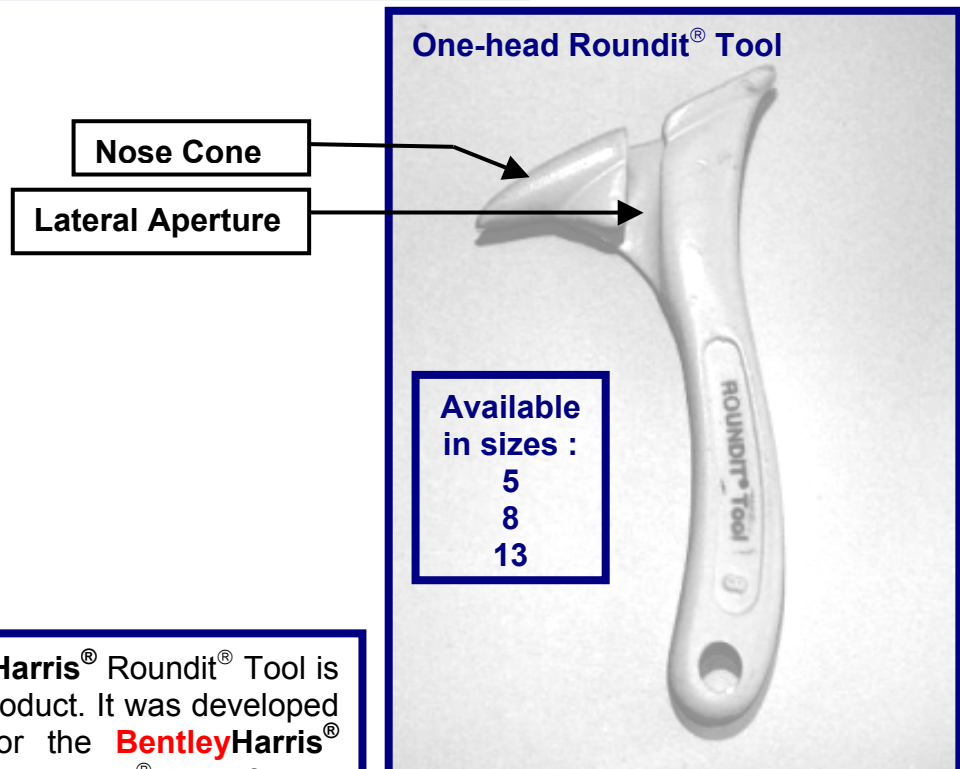
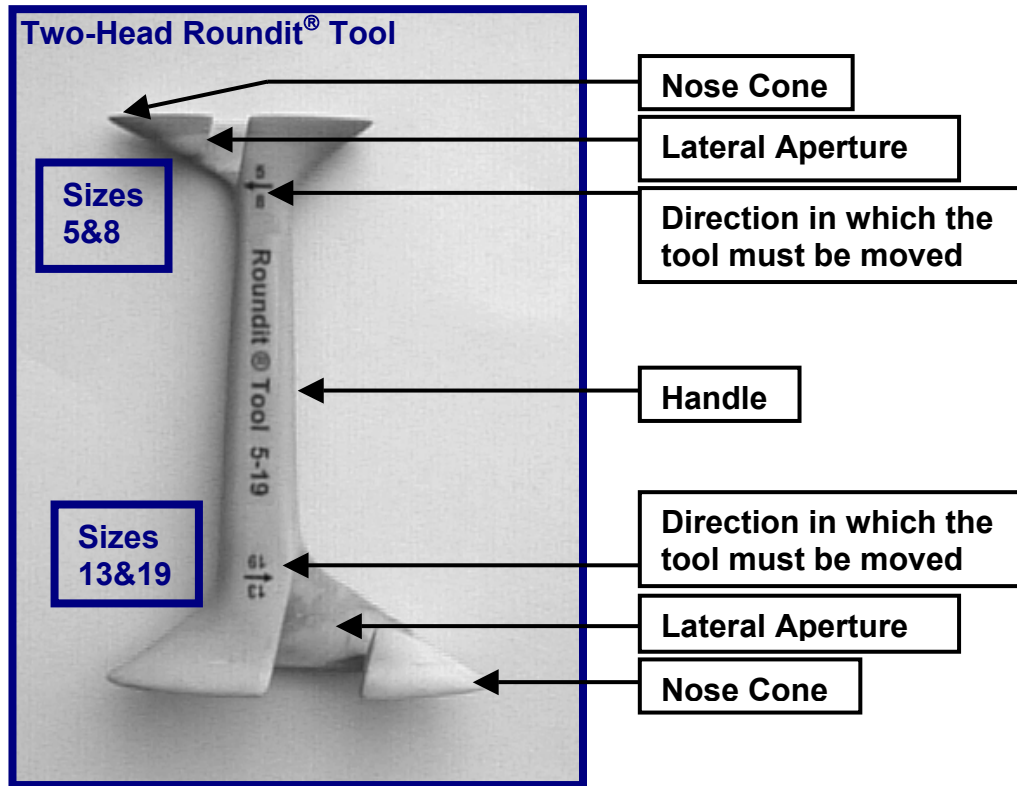

The **BentleyHarris®** Roundit® Tool is a patented product. It was developed specifically for the **BentleyHarris®** sleeves in the Roundit® 2000 family. It is not authorized for use on any other product.

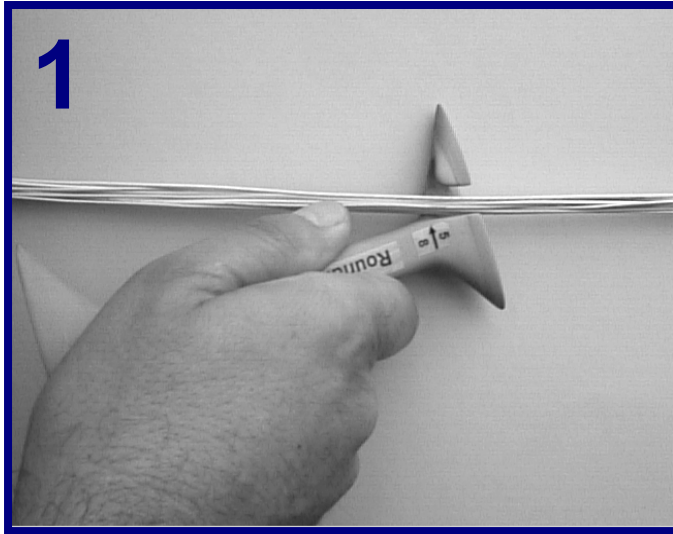

Select the head of the tool that fits the right size of **Roundit 2000FR**.
Insert the harness on the Roundit®-Tool by the lateral aperture

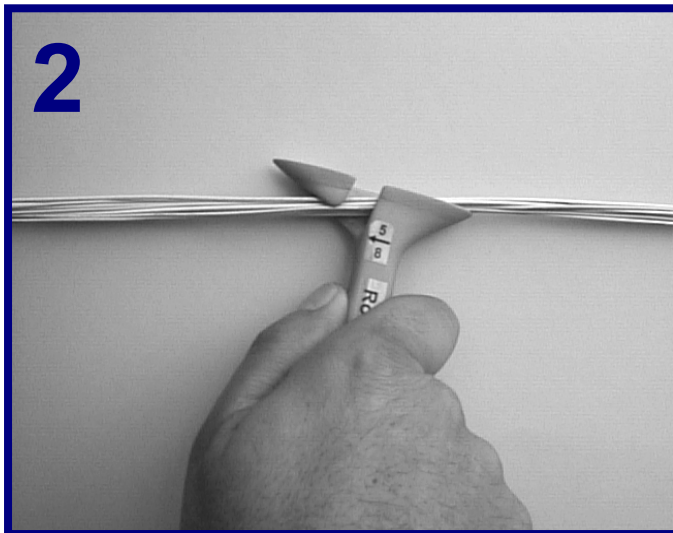

Group all the wire harness on the head of the Roundit®-Tool

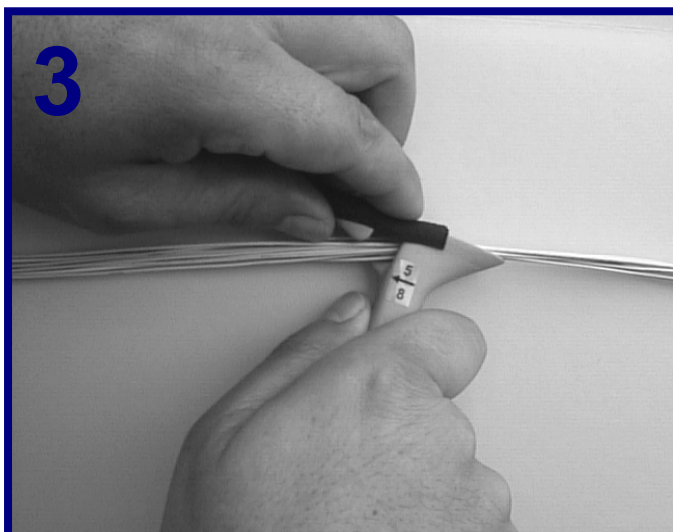

Insert **Roundit 2000FR** by the nose cone

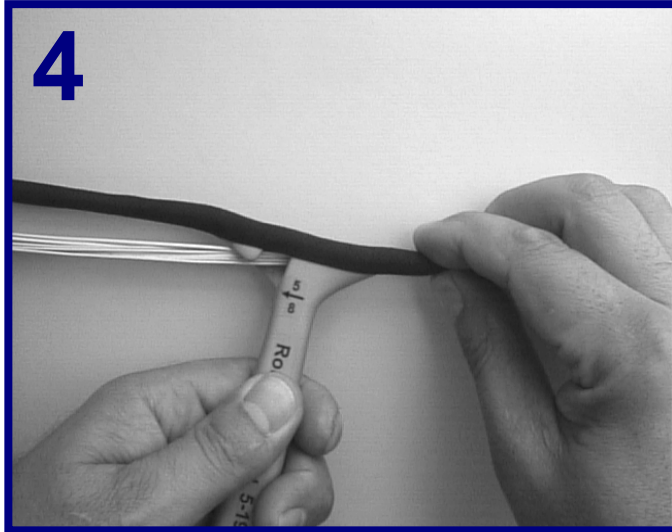

Assembly of the sleeve on the harness can be done by :

1. Moving the Roundit[®]-Tool along the wire and Roundit 2000FR (Applicable to long wire harness made on a table)
2. Moving Roundit 2000FR and the harness with the Roundit[®]-Tool fixed (Applicable to simple wire harness for serial manufacturing)
3. Moving Roundit 2000FR and the Roundit[®]-Tool along the wire harness (Applicable to small harness on table)

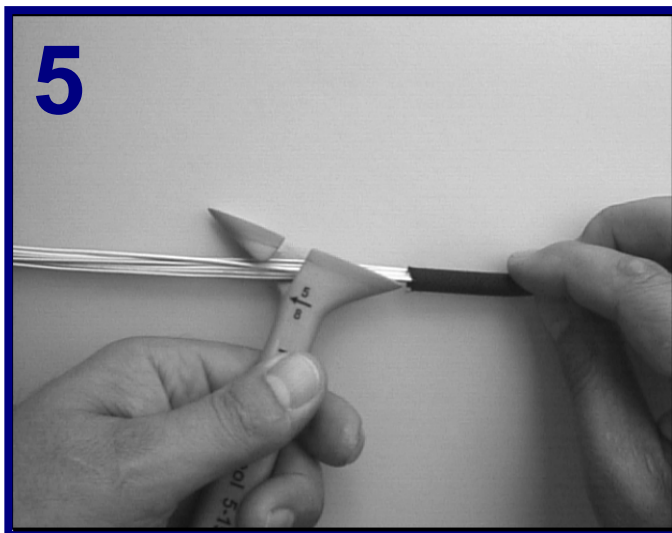

Take off the tool from Roundit 2000FR

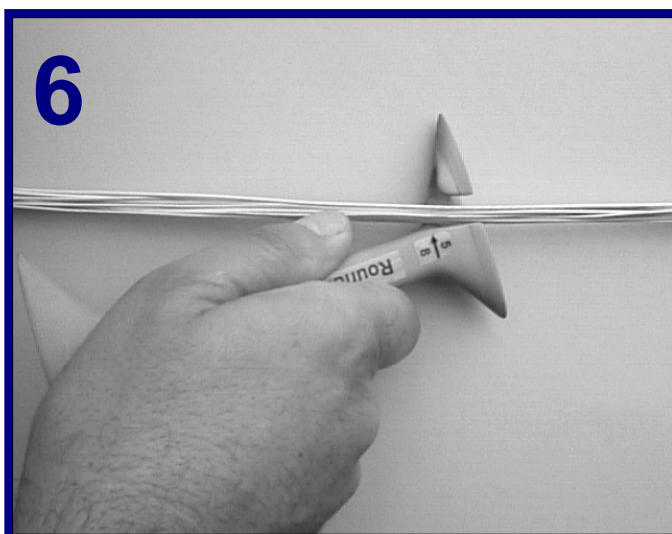

Take off the tool from the harness

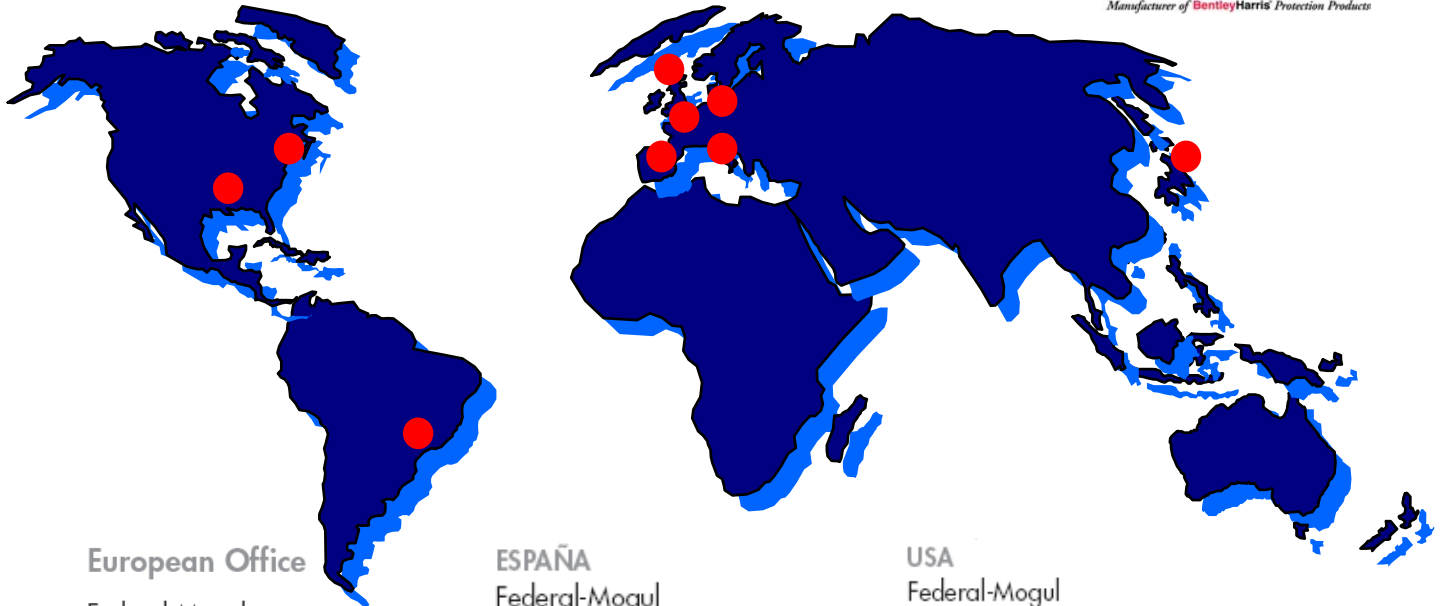

European Office

Federal-Mogul
Systems Protection Group S.A.S
L'Européen - Rue Jean Monnet
Parc Tertiaire de La Croix
F-60472 Compiègne Cedex
France
Tél : (33) (0)3 44 30 39 00
Fax : (33) (0)3 44 30 39 49

FRANCE

Systems Protection Group S.A.S.
69, Rue Henri-Laroche
60802 Crépy-en-Valois
Tel. : (33) (0)3 44 94 48 48
Fax. : (33) (0)3 44 97 63 67

DEUTSCHLAND

Federal-Mogul Burscheid GmbH
Systems Protection Group
Bürgermeister-Schmidt-Str. 17
51399 Burscheid
Tel. : (49) (0) 2174 69 17 15
Fax. : (49) (0) 2174 69 17 18

ENGLAND

Federal-Mogul
Systems Protection Group Ltd
P.O. Box 47 - Rooley Moor Rd.
Rochdale,
Lancashire OL12 7EZ
Tel. : (44) (0) 1706 640 100
Fax. : (44) (0) 1706 640 110

ESPAÑA

Federal-Mogul
Systems Protection Group
c/Progrés, 394
Barcelona, 08918
Tel. : (34) (0) 93 460 24 70
Fax. : (34) (0) 93 460 18 16

ITALIA

Federal-Mogul
Systems Protection Group
Via Reiss Romoli 122/11
10148 Torino
Tel./Fax : (39) 011 2263016

BRAZIL

Federal-Mogul
Systems Protection Group
773, Georg Rexroth Street
Diadema-SP
CEP 09951-270
Tel. : (55) 11 4070 6270
Fax. : (55) 11 4070 6272

JAPAN

Federal-Mogul
Systems Protection Group Inc.
4666 Ikebe-cho
Tsuzuki-ku, Yokohama-shi
224-0053
Tel. : (81) 45 938 8711
Fax. : (81) 45 938 8712

USA

Federal-Mogul
Systems Protection Group Inc.
1277 Joe Battle Boulevard
El Paso, TX 79936
Tel. : (1) 915 860 2300
Fax. : (1) 915 860 1243

Federal-Mogul
Systems Protection Group Inc.
241, Welsh Pool Road
Exton, PA 19341
Tel. : (1) 610 363 2600
Fax. : (1) 610 363 1727

Federal Mogul
Systems Protection Group Inc.
17199 North Laurel Park Drive,
Suite 401
Livonia, MI 48152-2679
Tel : (734) 542-9900
Fax : (734) 542-9857

The information and illustrations given herein are believed to be reliable. Federal-Mogul makes no warranties as to their accuracy or completeness and disclaims any liability in connection with their use. Federal-Mogul's only obligations are those in the standard term of sale for this product and Federal-Mogul will not be liable for any consequential or other damages arising out of the use or misuse of this product. Users should make their own evaluations to determine the suitability of the product for specific applications.

©1998 Federal-Mogul Systems Protection Group, manufacturer of Bentley-Harris protection products